

EPOXY-COATED DUCTILE IRON DOUBLE FLANGE CHECK VALVE

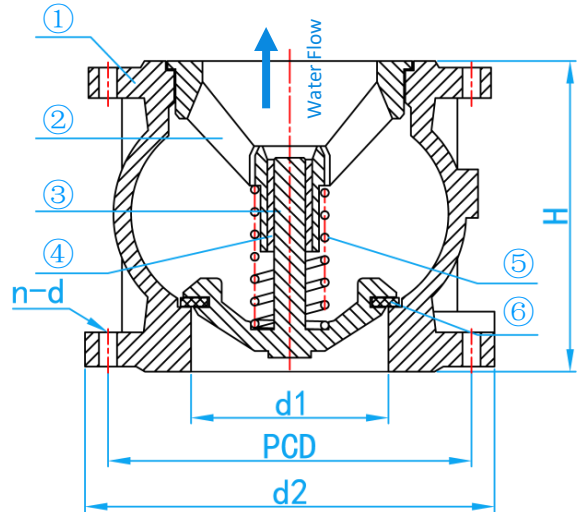

COMPLY WITH BS 5153:1974
BS 4504-3.2:1999
BS EN 545:2010
AS/NZS 4020:2018
SS 375:2015
SS 270:2015



CROSS SECTIONAL VIEW

STANDARD SPECIFICATIONS

Nominal Pressure	PN16
Sealing Test Pressure	1.76Mpa
Strength Test Pressure	2.4Mpa
Operating Temperature	-10 ~ 120°C

COMPONEN PARTS

ITEM	PARTS	MATERIAL
1	Body	Epoxy-coated Ductile Iron
2	Guide	AISI304
3	Disc	Ductile Iron
4	Guiding	Brass
5	Spring	AISI316
6	Seat	EPDM

DIMENSIONS

SKU	DN (mm)	d1 (mm)	PCD (mm)	d2 (mm)	H (mm)	n-d (mm)	WEIGHT (Kg)
CVDIN080F	80	80	160	200	140	8-19	10.8
CVDIN100F	100	101	180	220	170	8-19	13.5
CVDIN150F	150	145	240	285	230	8-23	30.0
CVDIN200F	200	194	295	340	301	12-23	47.5
CVDIN250F	250	245	355	405	370	12-26	70.5
CVDIN300F	300	300	400	460	410	12-26	105.0